

Technical Note

Using COPYBACK Operations to Maintain Data Integrity in NAND Flash Devices

Introduction

NAND Flash devices are no longer limited to mobile mass storage applications. They are being designed into increasingly complex and diverse systems to store operating systems and other critical data. Requirements for maintaining data integrity are more stringent for these applications than for mass storage devices. Even a single uncorrectable bit error that is not critical for many types of mass storage applications becomes a concern for embedded applications and other designs migrating to NAND Flash storage.

The host must implement application-level data management for NAND Flash to be an effective memory solution and for data integrity to be maintained. COPYBACK operations, which are sometimes referred to as INTERNAL DATA MOVE (IDM) operations, play a key role in maintaining data integrity in the NAND Flash device. This technical note describes how to use COPYBACK operations.

Preventing Data Errors in NAND Flash Devices

When moving data within a NAND Flash device, data errors can occur the same way they occur when the device is programmed and read. Some of the common mechanisms that cause data errors are described in Micron Technical Note [TN-29-17: "NAND Flash Design and Use Considerations."](#)

Because of these error mechanisms, all NAND Flash devices require error correction code (ECC). ECC helps protect against PROGRAM and READ errors. However, using COPYBACK operations without external data output (and data input, if required) can lead to errors beyond ECC protection limits. When the number of data errors exceeds ECC protection limits, data integrity is compromised, and application-level failures can occur.

Inputting/Outputting Data During COPYBACK Operations

Using COPYBACK operations is the most efficient way to move data from one location to another within a NAND Flash device. When performing COPYBACK operations, data is not input or output external to the device. However, data integrity issues can occur if data input and output options are not used. Inputting and outputting data during COPYBACK operations enable data to be corrected and returned to its original programmed value, and it resets ECC to its maximum level of error correction capability. Resetting ECC also prevents the number of data errors from accumulating beyond the ECC error correction capability. This helps maintain data integrity over the operational life of the device.

When reading data out during COPYBACK operations, data errors can be detected by comparing READ data with ECC data. If data errors are detected, ECC data can be used to correct any bit errors within the ECC correction threshold prior to programming

(inputting) the data back into the NAND Flash device (as shown in Figure 1). If no data errors are detected, no data input is required. This method of checking and correcting data during COPYBACK operations minimizes the number of data errors occurring beyond the ECC error correction capability.

Figure 1: Flow for Maintaining Data Integrity via COPYBACK Operations

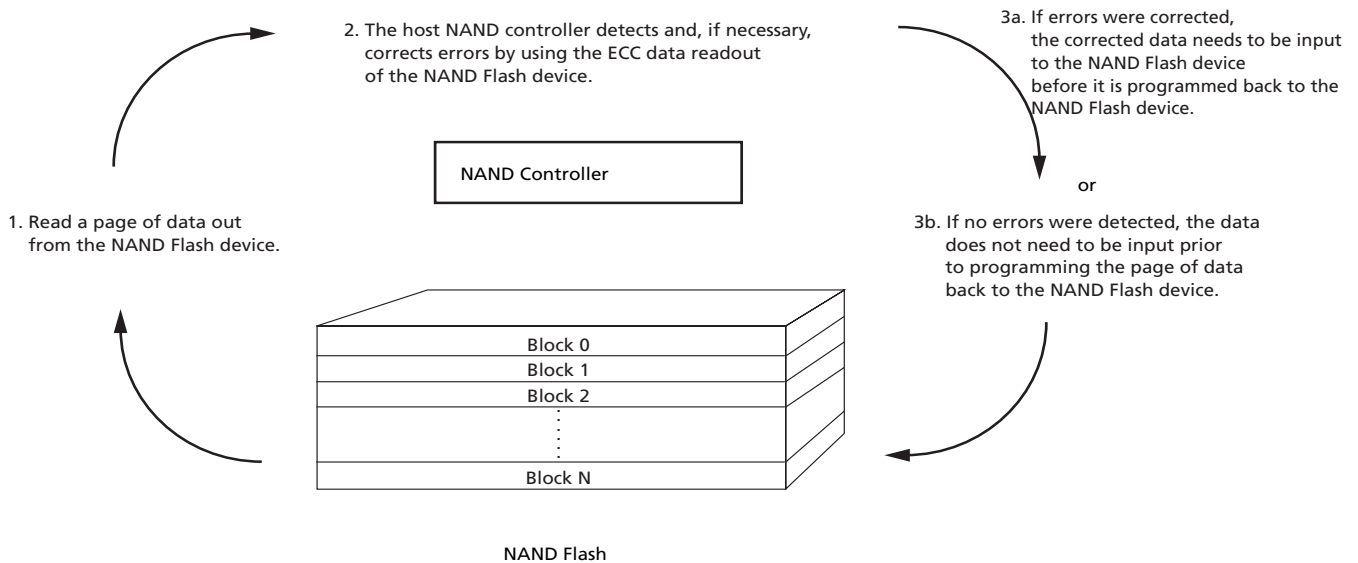

Programming Data During COPYBACK Operations

The most conservative approach to maintaining data integrity is to read data out of a NAND Flash device (output data), and then, if needed, program data back into the device (input data) during each COPYBACK operation. This provides the best chance of detecting and correcting bit errors that occur before they accumulate beyond correction capability. This is also the easiest method to implement because it does not require any device logic to determine whether there should be a check for data errors during any given COPYBACK operation.

Although data integrity is maintained, checking data in this way does reduce performance during COPYBACK operations. This is because data must be read out of, and potentially input back in to, the NAND Flash device prior to a PROGRAM operation. To determine whether outputting and inputting data during each COPYBACK operation is necessary for a given application, consider the following questions:

- Will decreased performance caused by inputting/outputting data during each COPYBACK operation negatively impact the application?
- How important is data integrity to the application?
- Can the application keep track of data that has been checked for data errors and data that has not been checked?
- How much ECC margin does the application have compared with the minimum required ECC capability of the device?

Conclusion

As data integrity and operational life requirements increase for applications using NAND Flash devices, the application-level management functions that maintain a NAND Flash array must change to meet those requirements. Checking for data errors during COPYBACK operations is maintaining data integrity in NAND Flash devices.

For the latest information on Micron NAND Flash devices, go to www.micron.com.



8000 S. Federal Way, P.O. Box 6, Boise, ID 83707-0006, Tel: 208-368-3900
prodmtg@micron.com www.micron.com Customer Comment Line: 800-932-4992
Micron, the M logo, and the Micron logo are trademarks of Micron Technology, Inc.
All other trademarks are the property of their respective owners.



Revision History

Rev. A	10/08
• Initial release	